

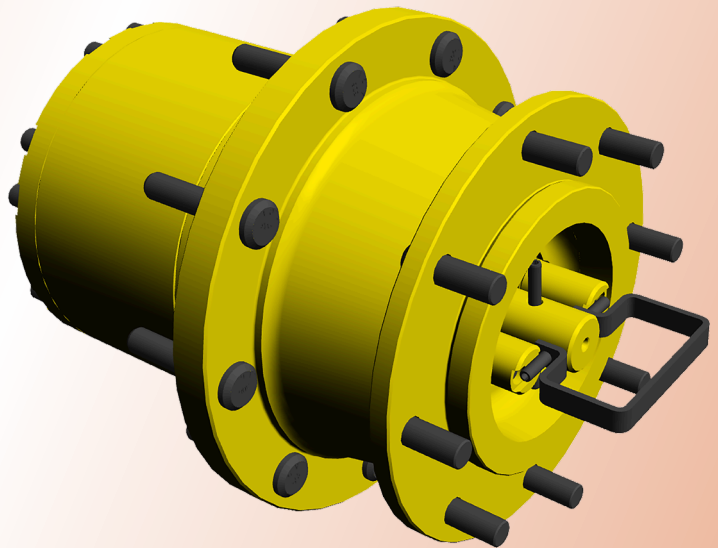

Power Wheel® Model 6B & 7 Plus TwisToTow®

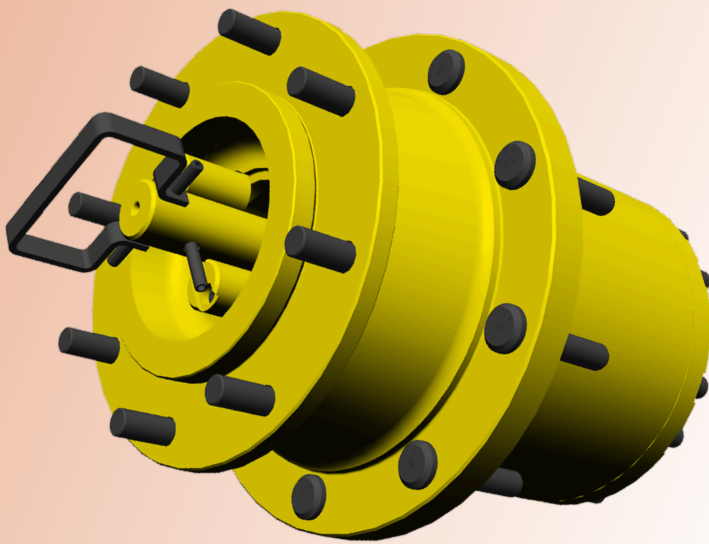

260-925-3200

www.auburngear.com

GENERAL SPECIFICATIONS

Model 6B

Max. Intermittent Output Torque^{1,2}.....50,000 lb-in (5,700 Nm)
 Max. Input Speed² (w/o park brake).....5,000 RPM
 Max. Input speed^{2,3} (w park brake).....3,600 RPM
 Approximate Weight.....140 lbs (64 kg)
 Oil Capacity⁴.....32 oz (950 cc)
 Max. Radial Load (@ pref. load center).....30,000 lbs (13,600 kg)

Model 7

Max. Intermittent Output Torque^{1,2}.....70,000 lb-in (7,900 Nm)
 Max. Input Speed² (w/o park brake).....5,000 RPM
 Max. Input speed^{2,3} (w park brake).....3,600 RPM
 Approximate Weight.....140 lbs (64 kg)
 Oil Capacity⁴.....32 oz (950 cc)
 Max. Radial Load (@ pref. load center).....30,000 lbs (13,600 kg)

¹ Depending on the duty cycle and the nature of the application, a normal continuous output torque of 1/3 to 1/2 of the maximum intermittent should yield satisfactory Power Wheel® life. Customer testing and application analysis is strongly recommended.

² If application exceeds published limit, contact Auburn Gear.

³ Bolt-on and A2 Series Parking brakes available. Please Contact Auburn Gear if required.

⁴ Oil capacity indicated is an approximation. Unit should be filled 1/2 full of recommended oil

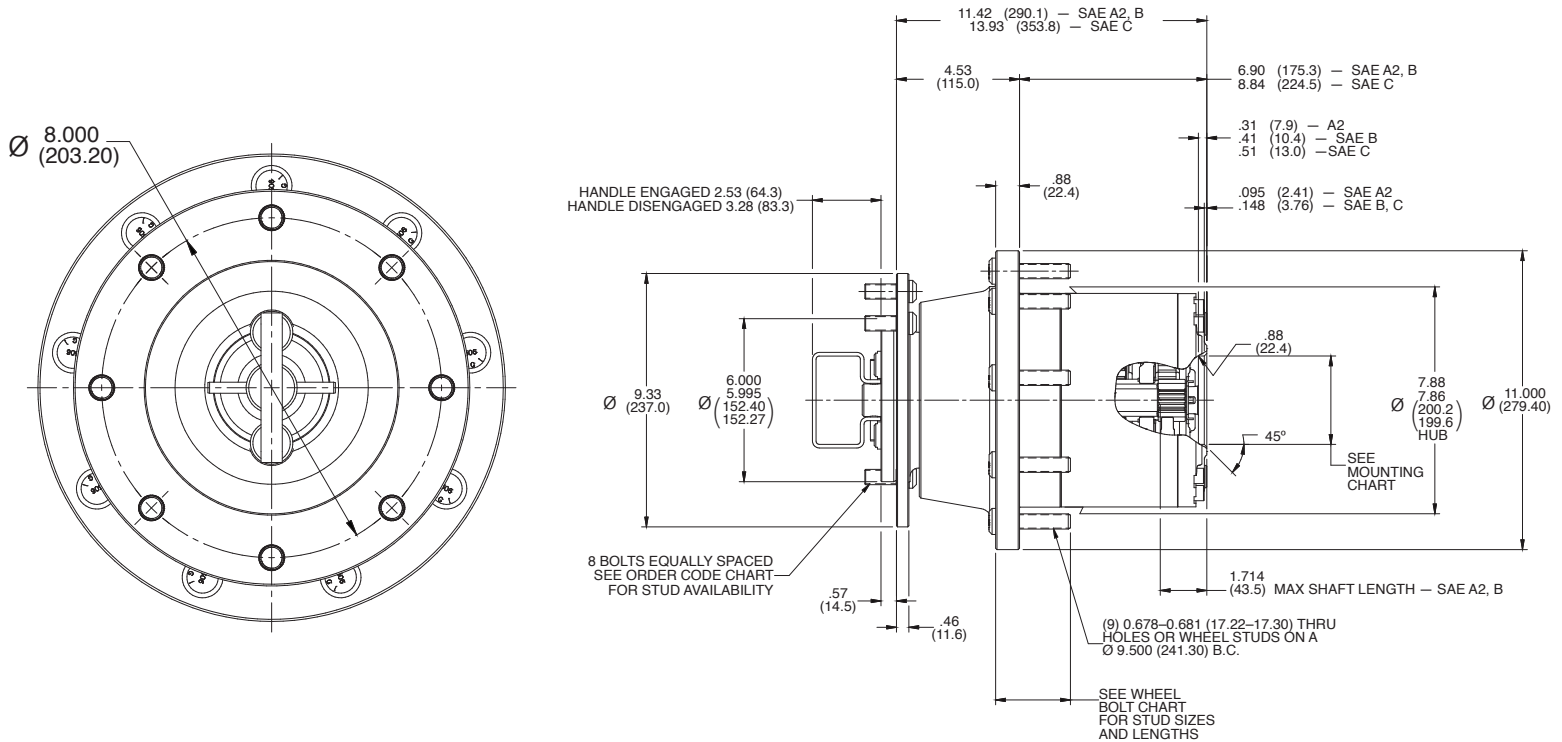

FEATURE CHART

SAE	# of Tapped Holes, Thread Size, and Bolt Circle	Pilot Diameter
A2	(2) 1/2"-13 UNC-2B on a 4.187" (106.35mm) B.C.	3.251"-3.256" (82.5mm-82.70mm)
B	(2) 1/2"-13 UNC-2B on a 5.75" (146.05mm) B.C.	4.001"-4.006" (101.62mm-101.75mm)
C	(4) 1/2"-13 UNC-2B on 6.735" (161.93mm) B.C. & (2) 5/8"-11 UNC-2B on 7.125" (180.97mm) B.C.	5.001"-5.006" (127.03mm-127.15mm)

FEATURE CHART

OPTIONS	DESCRIPTION	MAKE ALL SELECTIONS IN ONE COLUMN				ORDER CODES		USE OPTION ODER CODES TO BUILD ORDER NUMBER			
BASE MODEL	Model 6B Plus	*	*	*	*	6S3	6S3				
	Model 7 Plus	*	*			7S					
MOTOR PILOT/HUB	A2	*			*	A2F	A2F				
	SAE B	*		*		BF					
	SAE C		*			CF					
INPUT SPLINE	13T 16/32	*				13		13			
	14T 12/24		*			14					
	15T 16/32			*		15					
	1" 6B				*	6B					
RATIO OPTIONS	14.06:1	*	*	*	*	14					
	16.88:1	*	*	*	*	16					
	18.94:1	*	*			18					
	20.62:1	*	*	*	*	20					
	22.74:1	*	*	*	*	22					
	25.53:1	*	*		*	25					
	29.37:1	*	*			29					
	33.79:1	*	*			33			33		
HUB STUDS	None	*	*	*	*	00					
	1/2-20 x 2.50"	*	*	*	*	16					
	9/16-18 x 2.75"	*	*	*	*	18			18		
	5/8-18 x 2.98"	*	*	*	*	12					
SPINDLE OPTIONS	8 Thru Holes on 9.50" B.C.	*	*	*	*	FD3				FD3	
SPINDLE STUDS	None	*	*	*	*	00					
	1/2-20 x 1.62"	*	*	*	*	26					
	9/16-18 x 1.62"	*	*	*	*	27					27
	9/16-18 x 2.75" thd stud	*	*	*	*	18X					

EXAMPLE OF COMPLETE ORDER CODE: 6S3 A2F 13 33 18 FD3 27

Single Reduction Ratios are available (3.75, 4.50, 5.05, and 5.81:1. Contact Auburn Gear for configurations that can be created.

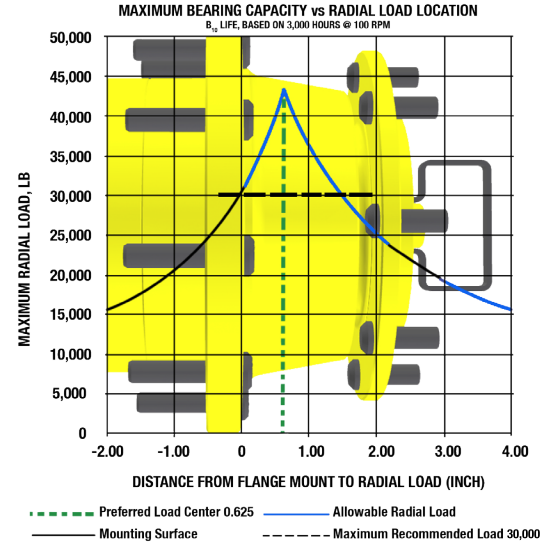
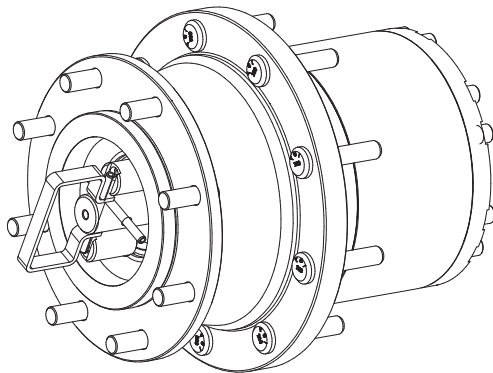

BEARING LOAD, LIFE & SPEED RELATIONS

$$LF = \frac{SF \times R}{R'}$$

R = Allowable resultant load for given location from mounting flange

R' = Anticipated load at location from mounting flange

LF = Life Factor from table (see below)

SF = Speed Factor from table (see below)

Output Speed (RPM)	SF	LF	Bearing Hours B-10 Life
5	2.456	.584	500
10	1.994	.719	1000
20	1.620	.812	1500
30	1.435	.886	2000
40	1.316	.947	2500
50	1.231	1.000	3000
60	1.165	1.047	3500
70	1.113	1.090	4000
80	1.069	1.130	4500
90	1.032	1.166	5000
100	1.000	1.231	6000
200	.812	1.289	7000
300	.719	1.342	8000
400	.659	1.390	9000
500	.617	1.435	10000

CAUTION: The same torsional loading constraints used in the driving mode must be used in the braking mode when braking through the Power Wheel® Drive gear set.

Providing Technology, Quality, & Customer Support Around the Globe



All specifications and data contained herein are nominal and subject to change without notice.
Specific applications should be referred to Auburn Gear for current information.