

Power Wheel® Service Manual

Model 6 Single Reduction

Wheel Drives



PHONE: (219) 925-3200
FAX: (219) 925-4725

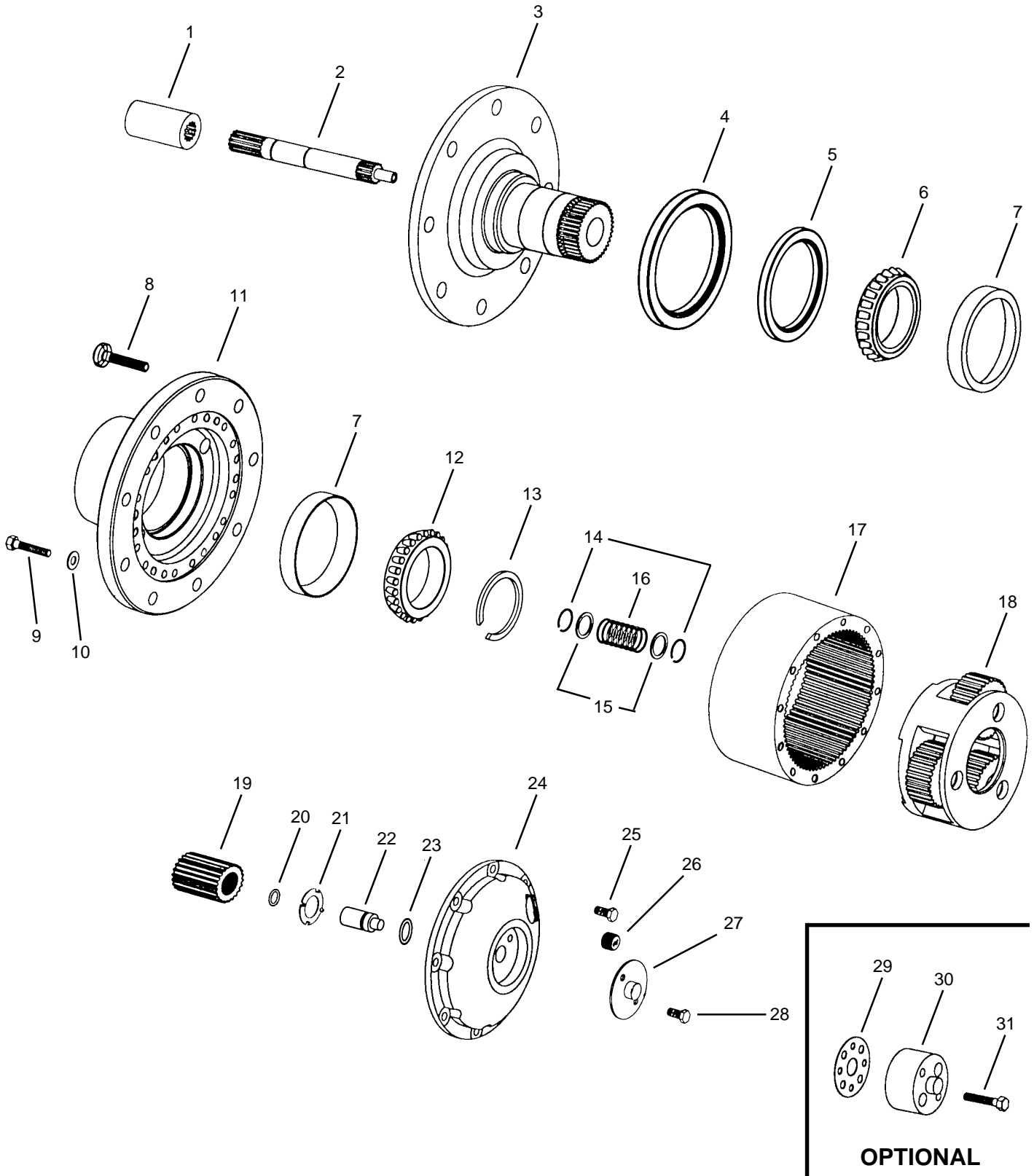

IDENTIFICATION

IMPORTANT: All Power Wheel units and kits are shipped with a nameplate that includes the Auburn Gear part number and order code as shown.

Example:



In addition to the nameplate, Power Wheel drives are stamped with an identification number which appears on the cover or hub flange as shown.

Example: **6000236-A-4-9**

When ordering parts, the information included on the nameplate or the stamped identification number is necessary to accurately identify the drive and obtain the correct replacement parts. Once this information has been obtained, contact Auburn Gear for the appropriate parts list.

DISASSEMBLY OF POWER WHEEL

STEP 1

Slide the coupling (1) from splines on input shaft (2).

STEP 2

Position the assembly upright on face of spindle (3).

STEP 3

Remove the disengage cover (27) if necessary.

STEP 4

Remove bolts (25) and the large cover (24) from the unit. The thrust washer (21) and the disengage plunger (22) usually remain attached to the large cover (24) when it is removed. Remove thrust washer (21), disengage plunger (22) and "O" ring (23) from the large cover (24).

STEP 5

Remove sun gear (19) and thrust washer (20), used in aluminum cover units only, from end of input shaft (2).

STEP 6

Remove the carrier assembly (18).

STEP 7

Remove the input shaft (2) from spindle (3). Remove the retaining rings (14), washers (15), and disengage spring (16) from input shaft (2) only if replacement is required.

STEP 8

Remove the 6 or 12 bolts (9) and washers (10) from hub (11) and remove ring gear (17). It may be necessary to strike ring gear (17) with a rubber mallet to loosen from hub (11).

STEP 9

Remove the retaining ring (13) from in front of the bearing cone (12) and lift hub (11) from spindle (3). If bearings are not a loose fit, it may be necessary to press spindle (3) from hub (11). **NOTE:** Use a retaining ring expander tool to remove retaining ring (13).

STEP 10

Remove the oil seals (4) and (5) and bearing cones (6 & 12) from hub (11). Inspect bearing cups (7) in position and remove only if replacement is required.

ASSEMBLY OF POWER WHEEL

STEP 1

Press new bearing cups (7) in each side of the hub (11). It is recommended that bearing cups (7) and cones (6 & 12) be replaced in sets.

STEP 2

Assemble bearing cone (6) into cup (7) at seal end of hub (11) and press a new seal (5) into hub (11). Install boot seal (4) on hub (11) if unit is so equipped.

STEP 3

Position spindle (3) upright on bench. Lubricate lips of seals (4 & 5) and lower hub (11) onto spindle (3). Hub (11) should be centered as it is lowered over spindle (3) to prevent seal damage.

STEP 4

Assemble bearing cone (12) over spindle (3) and into bearing cup (7). If bearings (6, 7, & 12), hub (11) or spindle (3) is replaced, a new retaining ring (13) is required for proper bearing setting. Do not re-use snap ring after it has been installed and removed from unit. Select the thickest retaining ring (13) that can be assembled into the ring groove of the splined end of spindle (3) above bearing cone (12). Bearing should have from .000 – .006 inches of end play when proper retaining ring (13) is installed.

STEP 5

Assemble a retaining ring (14) in groove opposite pilot end of input shaft (2). Assemble a washer (15), spring (16), a second washer (15), and a second retaining ring (14) in the middle grooves of input shaft (2). Some shafts have a shoulder and require only one retaining ring (14).

STEP 6

Assemble the splined end of the input shaft (2) down into spindle (3).

STEP 7

Assemble the carrier assembly (18) to spindle (3) at splines.

STEP 8

Clean mating surfaces and apply a bead of silicone sealant to face of hub (11) that mates with ring gear (17). {See instructions on sealant package.} Hub (11) is attached to ring gear (17) with 6 or 12 3/8-24 grade 8 hex head cap screws (9) and flat washers (10). Torque cap screws to 52 – 60 lb. ft. (70 – 81 Nm).

STEP 9

Assemble sun gear (19) over input shaft (2). Rotate sun gear (19) to align input shaft (2) to gear splines and gear teeth in carrier assembly (18).

STEP 10

For units with the aluminum cover (24) assemble the small thrust washer (20) over input shaft (2) and against shoulder of input shaft (2).

STEP 11

For units with the aluminum cover (24), lubricate "O" ring (23) and assemble in groove of the disengage plunger (22). Assemble disengage plunger (22) over end of input shaft (2) and against thrust washer (20). For units with cast iron cover (24), lubricate "O" ring (23) and assemble in groove inside cover hole, push plunger (22) into cover with pointed end facing inside of unit.

STEP 12

Assemble the thrust washer (21) with tangs engaged with cover (24). **NOTE:** A small amount of grease applied to the back side of thrust washer (21) will hold washer in place. Apply a bead of silicone sealant to end of face of ring gear (17). Assemble cover (24) aligning holes of cover and ring gear. Assemble the eight 5/16-18 x 1 inch hex head bolts (25). Torque bolts to 20 – 25 lb. ft. (27 – 34 Nm).

STEP 13

Assemble the disengage cover (27) with dimpled center protruding out if wheel is to be used to drive the vehicle. Assemble and torque the two 5/16-18 x 1/2 inch bolts (28). Torque bolts to 10 – 20 lb. ft. (13 – 27 Nm).

STEP 14

Invert the Power Wheel assembly and assemble the coupling (1), with counterbore out, to the input shaft (2).

STEP 15

After motor is assembled to drive or drive is sealed at spindle, fill with lubricant to proper level and replace all plugs.

NOTE: When installing a hydraulic motor to the Power Wheel drive it is necessary to place an "O" ring or gasket (not supplied by Auburn Gear) between the motor and the planetary drive. "O" ring sizes: SAE A 2-042, SAE B 2-155, SAE C 2-159.

CARRIER ASSEMBLIES

It is recommended that the carrier assembly (18) be replaced in its entirety to protect the integrity of the Power Wheel drive.

LUBRICATION RECOMMENDATIONS

IMPORTANT: POWER WHEEL PLANETARY DRIVES ARE SHIPPED WITHOUT LUBRICANT AND MUST BE FILLED TO THE PROPER LEVEL PRIOR TO START UP.

Observe lubrication recommendations given by the original equipment manufacturer. When specific recommendations are not available, use mild extreme pressure lubricant API-GL-5, No. 80 or 90 when filling the Power Wheel under normal temperature ranges between 0 - 120°F (-18 to 49°C). Power Wheel is to be half full of oil when unit is mounted level and horizontal. Use drain and fill plugs located in cover and ring gear. Oil is to be changed after first 50 hours of operation with subsequent changes every 1000 hours or yearly, which ever comes first. If unit is to be operated vertically, if ambient conditions are outside the specified range, or if the oil temperature exceeds 200°F (93°C) contact Auburn Gear for oil and level recommendations.

TOWING VEHICLE

CAUTION: The Power Wheel will not normally be damaged by towing; however, the hydraulic drive components may be damaged unless the Power Wheel is disengaged from the drive motor. Road speeds in excess of 25 MPH should be avoided unless clearly specified to be permissible by the equipment manufacturer.

TO DISENGAGE POWER WHEEL

CAUTION: For units equipped with the standard spring disconnect, assemble the disengage cover (27) with the dimpled center protruding inward. For units equipped with the optional quick disconnect, push in center plunger of disconnect.

STORAGE

A protective film is applied to the Power Wheel at the factory to prevent rust during shipment. Additional protection may be required if the Power Wheel is to be stored for an extended period of time.

SEALING COMPOUND

Silastic RTV732 sealer and General Electric Silimate RTV No. 1473 or RTV No. 1503 are currently recommended for sealing gasket surfaces. Sealant should be applied in a continuous bead, which should be centered on the surface to be sealed but should move to the inside of the hole at each bolt hole location. For service requirements order Auburn Gear part number 604101.

SPECIFICATIONS

Maximum intermittent output torque	22,000 lb. in. (2,485 Nm)
Maximum input speed	3,500 RPM
Oil capacity	25 oz (738 ml)

ITEM NO.	DESCRIPTION*	NO. USED IN ASS'Y.	ITEM NO.	DESCRIPTION*	NO. USED IN ASS'Y.
1	Coupling	1	17	Ring Gear	1
2	Input Shaft	1	18	Carrier Assembly	1
3	Spindle	1	19	Sun Gear	1
4	Boot Seal 604401	1	20	Retaining Ring	1
5	Oil Seal 14-00-044-010	1	21	Thrust Washer	1
6	Bearing Cone 04-01-101-35	1	22	Disengage Plunger	1
7	Bearing Cup 04-01-102-12	2	23	"O" Ring 614101	1
8	Wheel Bolt	9		Aluminum Cover 10-00-141-113 Cast Iron Cover 614101	
9	Hex Head Bolt (Grade 8)	6-12	24	Large Cover	1
10	Flat Washer 14-00-047-002	6-12		Aluminum Cover 14-02-039-004 Cast Iron Cover 603915	
11	Hub	1	25	Hex Head Bolt	8
12	Bearing Cone 04-01-101-17	1	26	Magnetic Plug 14-00-052-002	1
13	Retaining Ring Kit 14-02-410-003	1	27	Disengage Cover 14-02-039-005	1
14	Retaining Ring 613912	2	28	Hex Head Bolt 618305	2
15	Washer 14-02-193-002	2	29	Quick Disconnect Gasket	1
16	Disengage Spring 14-02-156-001	1	30	Quick Disconnect Assembly	1
			31	Hex Head Bolt	2

* Contact Auburn Gear with part number and order code of drive to obtain the appropriate parts list. Refer to parts list for the specific part numbers and quantities.

Model 6 Power Wheel® Service Kits

Part No.	Description	Included Items
14-02-410-003	Retaining Ring Kit	13 (7 Retaining Rings)
641008**	Bearing and Seal Kit	5, 6, 7, 12, 13 and 23
641017**	Seal Kit	5, 13 and 23

** Indicates kit also includes a tube of sealant, part number 604101.