

Power Wheel® Service Manual

Model 200 Double Reduction

Wheel Drives



PHONE:(260) 925-3200

FAX:(260) 925-4725

www.powerwheeldrives.com

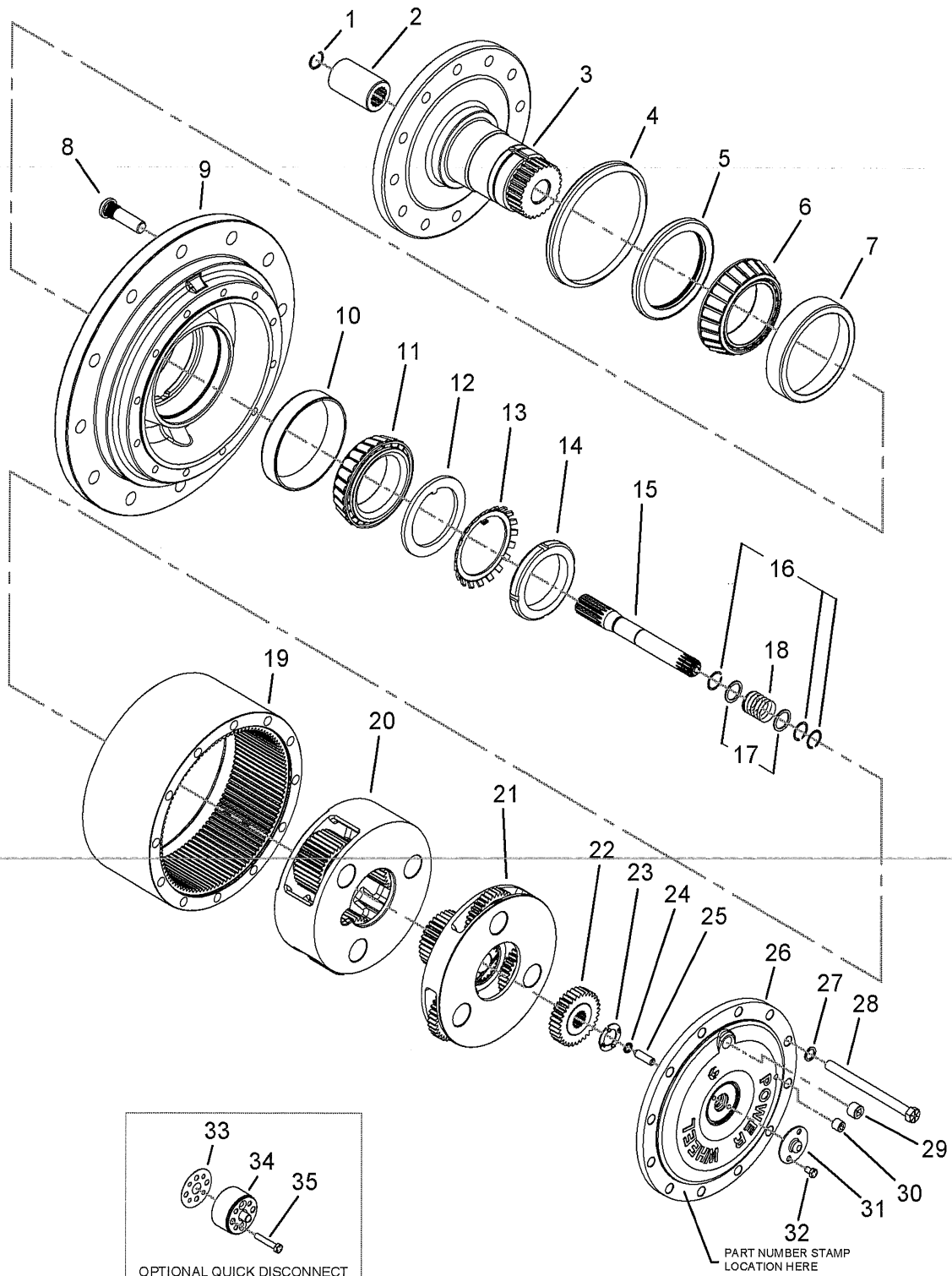

IDENTIFICATION

IMPORTANT: All Power Wheel units and kits are shipped with a label that includes the Auburn Gear part number, order code and work order.

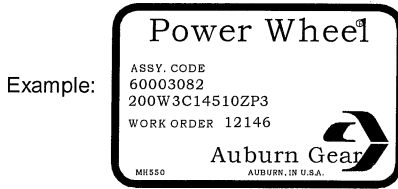

In addition to the label, Power Wheel drives are stamped with the last four digits of the part number and date code, which appears on the cover or hub flange as shown.

Example: **3082 12146**

When ordering parts, the information included on the label or the stamped part number is necessary to accurately identify the drive and obtain the correct replacement parts. Once this information has been obtained, contact Auburn Gear for the appropriate parts list.

DISASSEMBLY OF POWER WHEEL

STEP 1

Slide the coupling (2) out of spindle (3).

STEP 2

Position the assembly upright on face of spindle (3).

STEP 3

Remove the disengage cover (31) if necessary.

STEP 4

Remove twelve bolts (28), flat washers (27) and large cover (26). Disengage plunger (25) usually remains with large cover (26). Remove plunger (25) and "O" ring (24) from cover. The thrust washer (23) will not remain in position on the thrust face of large cover (26).

STEP 5

Remove primary sun gear (22) from end of input shaft (15).

STEP 6

Remove the primary carrier assembly (21).

STEP 7

Remove the secondary carrier assembly (20).

STEP 8

Remove the input shaft (15) from spindle (3). Remove the retaining rings (16), thrust washers (17), and disengage spring (18) from input shaft (15) only if replacement is required.

STEP 9

Remove ring gear (19) from hub (9). It may be necessary to strike ring gear (19) with a rubber mallet to loosen from hub (9).

STEP 10

One tab of lock washer (13) will be engaged in slot of bearing nut (14); bend tab back to release. Remove the bearing nut (14), lock washer (13) and thrust washer (12). **NOTE:** A special locknut wrench, 592A, is required for the removal of the bearing locknut. Contact Auburn Gear to purchase wrench and other service tools.

STEP 11

Place assembly in press with spindle (3) down on hub flange (9). Place material under spindle so not to damage when it's pressed out of hub. Care should be taken to avoid damaging splines and threads on spindle while pressing it out. **NOTE:** Bearing cone (11) has been designed with a press fit with respect to spindle (3). Considerable force will be required to remove cone from spindle. If a press is not available you will need the 609BB Spindle/Shaft removal tool. Place the small disk on the end of the spindle/shaft. Mount the cross tube to the hub. Turn the screw against the small disk, DO NOT use an impact gun. Turning the screw will force the spindle/shaft out of the bearing cone.

STEP 12

Remove the oil seal (5) & boot seal (4), if included and bearing cones (6 & 11) from hub (9). Inspect bearing cups (7 & 10) in position and remove only if replacement is required.

ASSEMBLY OF POWER WHEEL

STEP 1

Press new bearing cups (7 & 10) in each side of the hub (9). It is recommended that bearing cups (7 & 10) and cones (6 & 11) be replaced in sets.

STEP 2

Assemble bearing cone (6) into cup (7) at seal end of hub (9) and press a new seal (5) into hub (9). Install boot seal (4) on hub (9) if unit is so equipped.

STEP 3

Position spindle (3) upright on bench. Lubricate lips of seals (4) and (5) and lower hub (9) onto spindle (3). Hub (9) should be centered as it is lowered over spindle (3) to prevent seal damage.

NOTE: [On heavy duty seals (order code T) there is to be no lubrication on seal (5), spindle (3), or hub (9)].

STEP 4

Press inner bearing cone (11) onto shaft (1) until rollers just contact inner bearing cup (10) using bearing cone driver 609B. Install tab of thrust washer (12) into slot of spindle (3). Place lock washer (13) onto spindle (3).

STEP 5

Torque bearing nut (14) to 50 lb.-ft using tool 592A.

STEP 6

Rotate hub (9) several revolutions in each direction to allow bearings to seat.

STEP 7

Using an appropriate pick, check each roller of the inner bearing cone (11) for looseness.

STEP 8

If all rollers are tight, proceed to step 11.

STEP 9

With bearing nut tool 592A placed on bearing nut (14), tap end of bearing nut tool with an appropriate hammer to advance the inner bearing cone (11) further onto shaft (1).

STEP 10

Repeat steps 5 thru 9 until all inner bearing cone rollers are tight.

STEP 11

Identify and mark the target tab/slot combination required to achieve the recommended preload of 3/4 tab to 1 full tab. Refer to figures below.

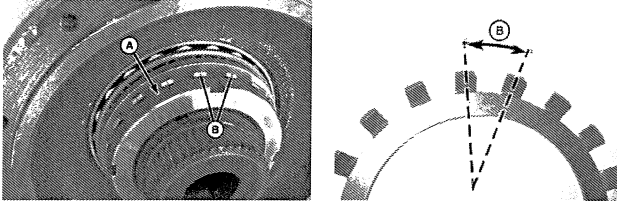

STEP 12

Set the bearing preload by advancing the bearing nut (14) onto the shaft (1) between 3/4 tab to 1 full tab. To advance the bearing nut to the preload position, tighten bearing nut using tool 592A until the slot and tab combination identified in Step 11 are aligned. Do not exceed 150 lb.-ft. If the appropriate slot and tab are not aligned prior to reaching 150 lb.-ft, tap end of bearing nut tool as described in Step 9 and continue to tighten bearing nut. Repeat as required until the appropriate tab and slot are aligned.

STEP 13

Secure bearing nut (14) by bending the lock washer tab into the aligned bearing nut slot.

STEP 14

Assemble thrust washers (17), spring (18) and two retaining rings (16) in the middle grooves of input shaft (15). Install a third retaining ring (16) in groove on splines at end of input shaft (15).

STEP 15

Insert the long splined end of the input shaft (15) with spring (18), thrust washers (17) and retaining rings (16) into spindle (3).

STEP 16

Assemble the secondary carrier assembly (20) on the spindle (3).

STEP 17

Clean mating surfaces and apply a bead of silicone sealant to face of hub (9) that mates with ring gear (19). See instructions on sealant

package. Assemble ring gear (19) to hub (9) being careful to align bolt holes.

STEP 18

Assemble the primary carrier assembly (21) into the ring gear (19). It will be necessary to rotate carrier to align secondary sun gear {part of primary carrier assembly (21)} with planet gear teeth in secondary carrier assembly (20). Assemble primary sun gear (22) over input shaft (15). Rotate primary sun gear (22) to align input shaft (15) to gear splines and gear teeth in primary carrier assembly (21).

STEP 19

Lubricate "O" ring (24) and assemble in groove inside cover (26) hole, push disengage plunger (25) into cover (26) with pointed end facing inside of unit.

STEP 20

Assemble the thrust washer (23) with tangs engaged with cover (26). **NOTE:** A small amount of grease applied to the backside of thrust washer (23) will hold washer in place. Apply a bead of silicone sealant to end of face of ring gear (19). Assemble cover (26) aligning holes of cover (26) and ring gear (19). Assemble the twelve 9/16-12 x 7 inch grade 8 bolts (28) and flat washers (27). Torque bolts to 120 - 130 lb.-ft. (163.2 - 176.8 N-m).

STEP 21

Assemble the disengage cover (31) with dimpled center protruding out if wheel is to be used to drive the vehicle. Assemble and torque the two 5/16-18 x 1/2 inch bolts (32). Torque bolts to 10 - 20 lb.-ft. (13.6 - 27.1 N-m).

STEP 22

If required, assemble a new retaining ring (1) into groove in inside diameter of coupling (2). Invert the Power Wheel assembly and assemble the coupling (2), with end nearest retaining ring (1) out onto the input shaft (15). **NOTE:** Coupling (2) must be assembled to input shaft so that end with retaining ring (1) is nearest motor or spindle side of drive.

STEP 23

After motor is assembled to drive or drive is sealed at spindle, fill with lubricant to proper level and install pipe plug (27) torque to 11-25 lb.-ft. (14.9 - 33.9 N-m).

NOTE: When installing a hydraulic motor to the Power Wheel drive it is necessary to place an "O" ring or gasket (not supplied by Auburn Gear) between the motor and the planetary drive. "O" ring sizes: SAE A 2-042, SAE B 2-155, SAE C 2-159.

CARRIER ASSEMBLIES

It is recommended that the primary and secondary carrier assemblies (20 & 21) be serviced in their entirety to protect the integrity of the Power Wheel drive.

LUBRICATION RECOMMENDATIONS

IMPORTANT: POWER WHEEL PLANETARY DRIVES ARE SHIPPED WITHOUT LUBRICANT AND MUST BE FILLED TO THE PROPER LEVEL PRIOR TO START UP.

Observe lubrication recommendations given by the original equipment manufacturer. When specific recommendations are not available, use mild extreme pressure lubricant API-GL-5, No. 80 or 90 when filling the Power Wheel under normal temperature ranges between 0 - 120°F (-18 to 49°C). Power Wheel is to be half full of oil when unit is mounted level and horizontal. Use drain and fill plugs located in cover. Oil is to be changed after first 50 hours of operation with subsequent changes every 1000 hours or yearly, whichever ever comes first. If unit is to be operated vertically, if ambient conditions are outside the specified range, or if the oil temperature exceeds 200°F (93°C) contact Auburn Gear for oil and level recommendations.

TOWING VEHICLE

CAUTION: The Power Wheel will not normally be damaged by towing; however, the hydraulic drive components may be damaged unless the Power Wheel is disengaged from the drive motor. Road speeds in excess of 25 MPH should be avoided unless clearly specified to be permissible by the equipment manufacturer.

TO DISENGAGE POWER WHEEL

CAUTION: For units equipped with the standard spring disconnect, assemble the disengage cover (31) with the dimpled center protruding inward. For units equipped with the optional quick disconnect, push in center plunger of disconnect (34).

STORAGE

A protective film is applied to the Power Wheel at the factory to prevent rust during shipment. Additional protection may be required if the Power Wheel is to be stored for an extended period of time.

SEALING COMPOUND

Silastic RTV732 sealer and General Electric Silimate RTV No. 1473 or RTV No. 1503 are currently recommended for sealing gasket surfaces. Sealant should be applied in a continuous bead, which should be centered on the surface to be sealed but should move to the inside of the hole at each bolt hole location. For service requirements order Auburn Gear part number 604101.

SPECIFICATIONS

Maximum intermittent output torque 200,000 lb. in. (22,600 N-m)
 Maximum input speed 5,000 RPM
 Oil capacity 110 oz (3,250 cc)

ITEM NO.	DESCRIPTION*	NO. USED IN ASS'Y.	ITEM NO.	DESCRIPTION*	NO. USED IN ASS'Y.
1 ***	Retaining Ring	1	19	Ring Gear	1
2	Coupling	1	20	Secondary Carrier Assembly	1
3	Spindle	1	21	Primary Carrier Assembly	1
4 ***	Boot Seal 604411	1	22	Primary Sun Gear	1
5	Oil Seal	1	23	Thrust Washer	1
6	Bearing Cone	1	24	"O" Ring	1
7	Bearing Cup	1	25	Disengage Plunger	1
8	Wheel Bolt	12	26	Cover	1
9	Hub	1	27	Flat Washer	12
10	Bearing Cup	1	28	Hex Head Bolt	12
11	Bearing Cone	1	29	Magnetic Plug 14-00-052-002	1
12	Thrust Washer 619333	1	30	Pipe Plug 03-04-101-09	1
13	Lock Washer 605006	1	31	Disengage Cover	1
14	Bearing Nut 614917	1	32	Hex Head Bolt	2
15	Input Shaft	1	OPTIONAL QUICK DISCONNECT		
16	Retaining Ring	3	33	Gasket 904501	1
17	Thrust Washer	2	34	Quick Disconnect 949001	1
18	Disengage Spring	1	35	Bolt Hex Head 618316	2

* Contact Auburn Gear with part number and order code of drive to obtain the appropriate parts list.

Refer to parts list for the specific part numbers and quantities.

*** Not required in all assemblies

Model 200 Power Wheel® Service Kits

Part No.	Description	Included Items
592A	Bearing Locknut Tool	Not Shown
609B	Bearing Cone Driver	Not Shown
609BB	Spindle/Shaft Drive Tool	Not Shown
641053**	Bearing & Seal Kit	5,6,7,10,11,13,24
641061**	Seal Kit	5,13,24

** Indicates kit also includes a tube of sealant, part number 604101

Power Wheel® is a registered trademark of Auburn Gear