

Auburn Gear

Engineered Drive Solutions

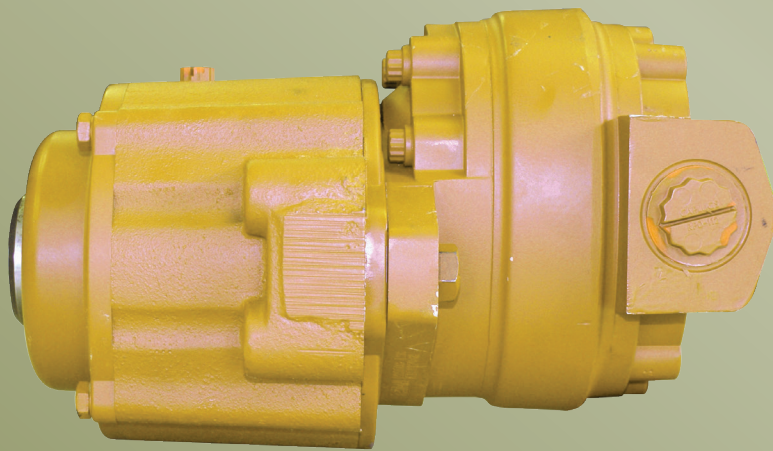
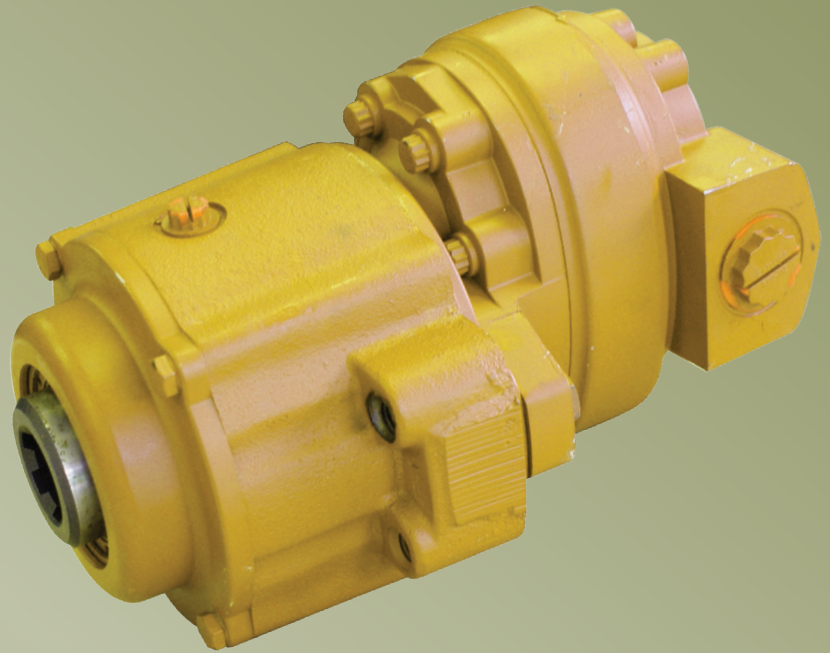

— **Power Wheel[®]** —

— **Model 3 PTO Drive** —

Power Wheel® Model 3 PTO Drive

FEATURE CHART: MODEL 3 PTO DRIVES

Options	Description	Make All Selections In One Column	Order Codes	Use Option Order Codes to Build Order Number
Base Model	Model 3	*	3T	3T
Pump Pilot/Hub	SAE B	*	B	B
Pump Shaft Spline	13T 16/32	*	13	13
Ratio Options	1:3.60	*	03	03
Input Shaft Options	6T-1.375" Female	*	A4	A4
Example of complete order code:				3T B 13 03 A4

GENERAL SPECIFICATIONS

Max. Input RPM.....	540 RPM
Max. Continuous Input HP.....	36 HP (26.8 kw)
Max Intermittent Input HP.....	60 HP (44.7 kw)
Max. Operating Temp.....	225° F (107° C)
Max. Case Pressure.....	30 PSI (2.1 bar)

PUMP MOUNTING CHART

SAE	# of Tapped Holes, Thread Size and Bolt Circle	Pilot Diameter
B	(2) 1/2"-UNC-2B Threaded Holes on a 5.75" (146.1mm) B.C.	4.001"-4.006" (101.63mm-101.75mm)

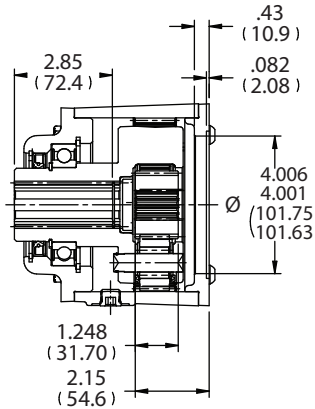
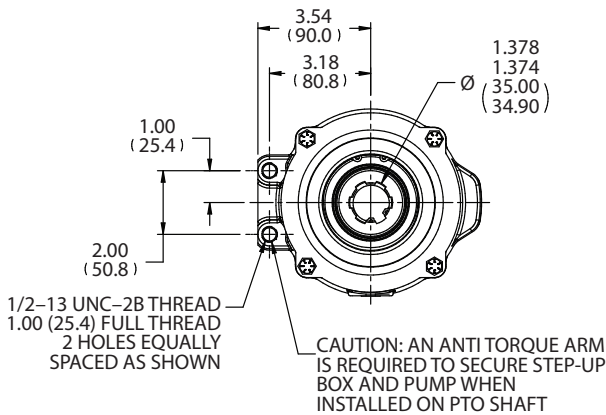

OUTPUT SHAFT ROTATION SAME AS MOTOR SHAFT ROTATION

MOTOR MOUNT REQUIRES CUSTOMER SUPPLIED O-RING SAE "B" 2-155

