



**Non-Powered Units
Power Wheel[®]
Planetary Gear Drive**

Non-Powered Units

Why should you specify a NON-POWERED UNIT?

1. In a 4x2 vehicle arrangement it allows the design engineer to use the same frame structure for the drive and dead wheels, which reduces the number of parts required.
2. The wheel end equipment, from front to rear, will mount identically, which will allow a machine builder to buy wheels/rims in greater volume.
3. It's cost effective!

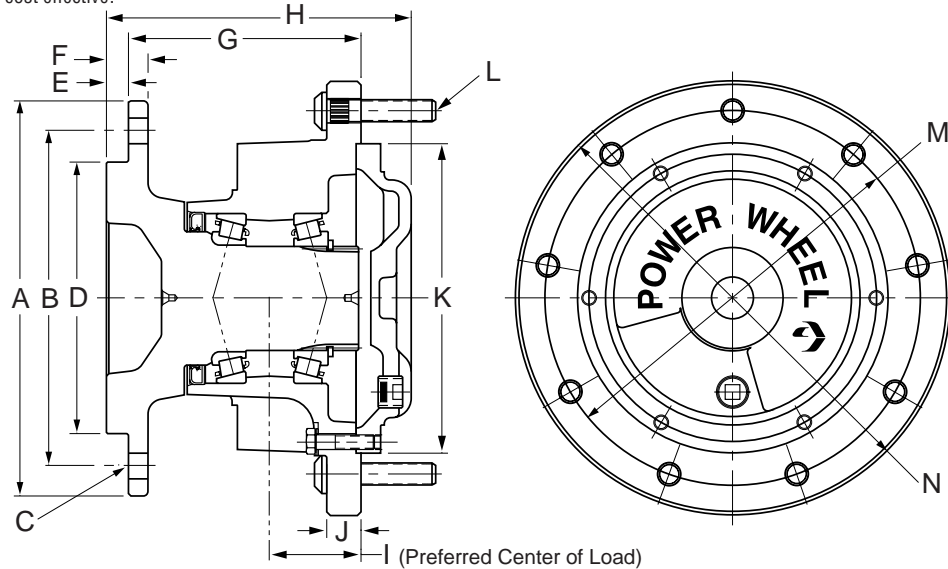

LOAD BEARING CAPACITIES

MODEL	MAX. RADIAL LOAD lb (kg)*
6N1	10,000 (4,550)
6N3	10,000 (4,550)
8N1	16,000 (7,250)
8N5	16,000 (7,250)
82N1	18,800 (8,530)
0N2	25,000 (11,340)

*See appropriate Power Wheel Model Catalog for bearing curve data.

FEATURE CHART: NON-POWERED UNITS

OPTIONS	DESCRIPTION	MAKE ALL SELECTIONS WITHIN ONE COLUMN				ORDER CODES	USE OPTION ORDER CODES TO BUILD ORDER NUMBER
MOUNT	6N1 6N3 8N1 8N5 82N1 0N2	<input type="checkbox"/>	<input type="checkbox"/>	<input type="checkbox"/>	<input type="checkbox"/>	6N1 6N3 8N1 8N5 82N1 0N2	6N1
WHEEL STUDS	¹ / ₂ by 2.50 ⁹/₁₆ by 2.75 ⁵ / ₈ by 2.37 ³ / ₄ by 3.21 NONE	<input type="checkbox"/>	<input type="checkbox"/>	<input type="checkbox"/>	<input type="checkbox"/>	5 7 8 11 0	7
Select desired characteristics from chart, note correct order codes, and order using sample format shown at right:							6N1 7

BOLDFACE INDICATES REGULAR VOLUME PRODUCED ITEMS WITH BEST AVAILABILITY. Contact Auburn Gear for additional features available.

MOUNTING CHART

MODEL	A	B	C	D	E	F	G	H	I	J	K	L	M	N
6N1 (in)	10.0	8.500	0.666-0.654 (8) holes equally spaced	6.895/6.865	0.57	1.07	5.88	7.72	2.31	0.88	7.86	0.611-0.604 (9) holes equally spaced	9.500	11.00
(mm)	254	215.9	16.92-16.61 (8) holes equally spaced	175.13/174.37	14.5	27.2	149.4	196.1	58.7	22.4	199.6	15.52-15.34 (9) holes equally spaced	241.30	279.4
6N3 (in)	7.0	5.500	0.500-13 UNC-2B (5) holes eq. spaced	3.999/3.994	0.40	0.94	5.19	6.86	2.31	0.88	7.86	0.611-0.604 (9) holes equally spaced	9.500	11.00
(mm)	177.8	139.70	12.70-13 UNC-2B (5) holes eq. spaced	101.58/101.45	10.2	23.9	131.8	174.2	58.7	22.4	199.6	15.52-15.34 (9) holes equally spaced	241.30	279.4
8N1 (in)	10.0	8.500	0.666-0.654 (8) holes equally spaced	6.878/6.872	0.52	1.25	5.35	6.93	2.47	0.76	10.625	0.681-0.678 (8) holes equally spaced	12.375	13.80
(mm)	254	215.9	16.92-16.61 (8) holes equally spaced	174.70/174.55	13.2	31.8	135.9	176.0	62.7	19.3	269.88	17.30-17.22 (8) holes equally spaced	314.33	350.5
8N5 (in)	10.91	9.500	0.625-11 UNC-2B (8) holes eq. spaced	8.000/7.995	0.62	1.25	4.00	6.73	1.22	0.96	10.625	0.850-0.847 (10) holes equally spaced	13.187	15.50
(mm)	277.1	241.30	15.88-11 UNC-2B (8) holes eq. spaced	203.20/203.07	15.7	31.8	101.6	170.9	31.0	24.4	269.88	21.59-21.51 (10) holes equally spaced	334.95	393.7
82N1 (in)	10.91	9.500	0.75-10 UNC-2B (8) holes equally spaced	8.000/7.995	0.73	1.5	5.37	7.16	2.26	0.76	10.625	0.681-0.678 (8) holes equally spaced	12.375	13.80
(mm)	277.1	241.30	19.1-10 UNC-2B (8) holes equally spaced	203.20/203.07	18.5	38.1	136.4	181.9	57.4	19.3	269.88	17.30-17.22 (8) holes equally spaced	314.33	350.5
0N2 (in)	12.44	10.500	0.75-16 UNF-2B (12) holes equally spaced	9.000/8.995	0.67	1.56	5.25	13.49	1.66	1.12	14.455	0.850-0.847 (10) holes equally spaced	16.750	19.00
(mm)	315.98	266.70	19.1-16 UNF-2B (12) holes equally spaced	228.60/228.47	17.0	39.6	133.4	342.7	42.2	28.5	367.16	21.59-21.51 (10) holes equally spaced	425.45	482.6

